

# Skid unit with a membrane pump

UTV  
Medium pressure

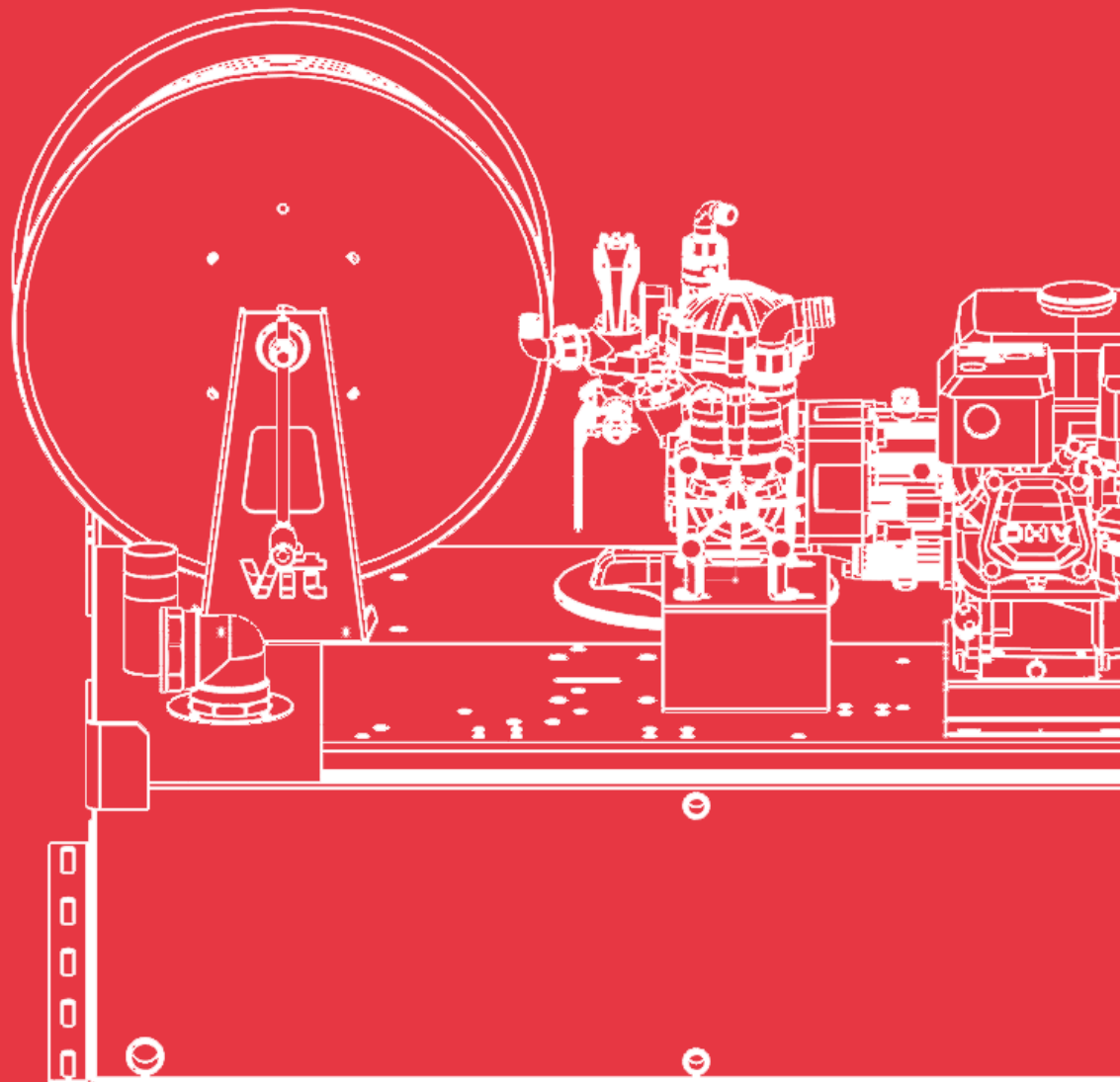

# UTV skid unit with a membrane pump

Medium pressure | Up to 40 bar

Rapid intervention skid units designed for light UTV vehicles, equipped with membrane pumps up to 40 bar with a maximum flow of up to 36 L/min.

- High-quality components and great replacement part availability
- Resistant tanks made of polyethylene.
- The best quality/price ratio
- 2 year warranty



## What is included?

|                            |                                    |
|----------------------------|------------------------------------|
| <b>Motor</b>               | <b>Gasoline</b> (6.5HP)            |
| <b>Membrane pump</b>       | 36 L/min.   40 bar                 |
| <b>Quick attack winder</b> | Equipped with a high-pressure hose |
| <b>Water tank</b>          | 150 L   320 L                      |
| <b>Attack nozzle</b>       | Water                              |
| <b>Suction oversleeve</b>  | 5 m long                           |

## Uses

|                                    |                  |
|------------------------------------|------------------|
| <b>Wildland fires</b>              | Recommended use  |
| <b>Container and vehicle fires</b> | Recommended use  |
| <b>Cleaning and unclogging</b>     | Less recommended |

# 1 Motor pump unit

Available options. 4-stroke gasoline combustion motors and membrane pumps.



| Motor       | Power* | Pump | Max. pressure** | Max. flow** |
|-------------|--------|------|-----------------|-------------|
| B&S XR950   | 6,5 HP | AR30 | 40 bar          | 36 l/min    |
| Honda GX160 | 4,8 HP | AR30 | 40 bar          | 36 l/min    |

Gasoline motor.

\* The nominal engine power indicated in this document is the net power tested on a production engine for the engine model pursuant to SAE J1349 (HONDA) / SAE J1940 (Briggs & Stratton) at a specific speed. This value may vary in mass produced motors. The actual output power of the engine installed on the end machine will vary depending on a number of factors such as the applicable engine operating speed, the environmental conditions, maintenance and other variables.

\*\* These values are at direct pump outlet.

\*\*\* The power, pressure and flow values are valid in working conditions: temperature 25°C at sea level. **IMPORTANT:** Engine power will decrease 3.5% for every 300 meters above sea level and 1% for each 5.6°C above 25°C.



**HONDA**



## 2 Water tank

Polyethylene tanks make the entire skid unit lighter. Vallfirest skid units with a polyethylene tank have an optimized design that provides a low center of gravity under the skid unit for greater vehicle stability. The shape can be adjusted to the dimensions of the loading area to optimize the available space.

- Made of polyethylene sheets via welding.
- 2 longitudinal breakwaters to prevent water from moving to the side to ensure vehicle stability.
- 1-1/2" filling spout on the top with couplings (Barcelona, Storz, DSP or others) to fill the tank from a hydrant or exterior pressurized water source.
- 5" vent tower on the top.
- A water level indicator over connecting ducts.
- A 3/4" drain to empty the tank.
- Pump return connection to fill the tank by suctioning water from a non-pressurized external water source.
- The tank connects to the vehicle with lateral fixing points or over forklift profile tubes (optional).
- Black natural color.

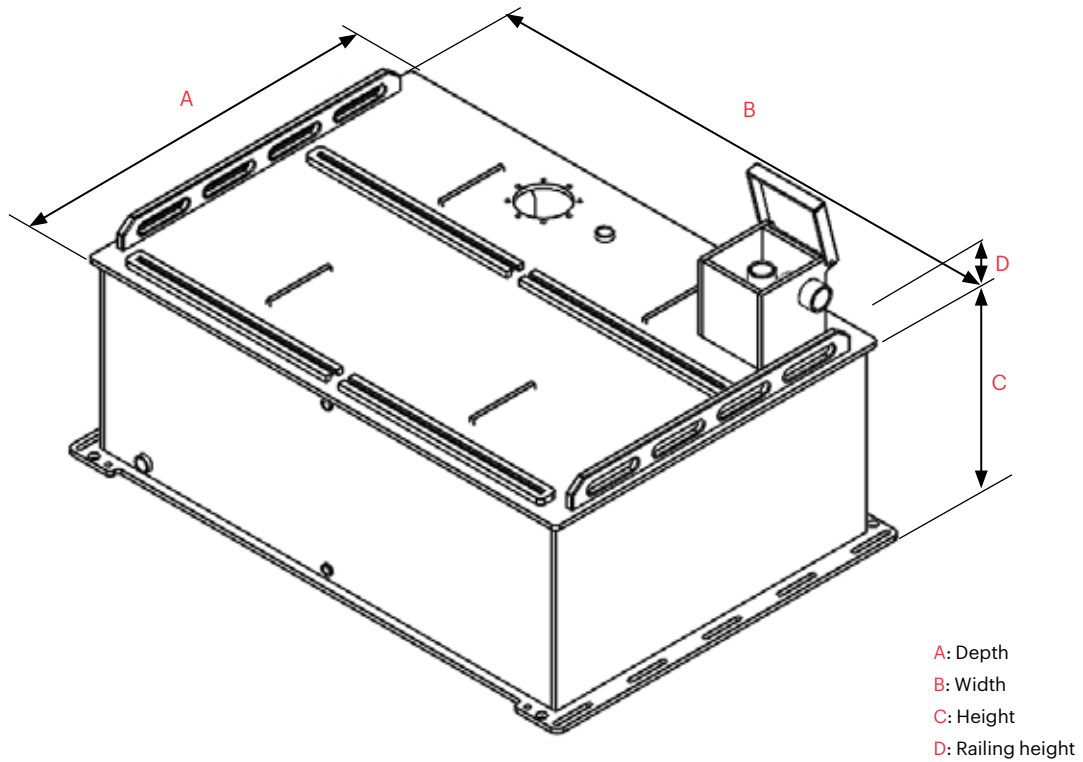

| Standard colors | Tank dimensions |        |        |        |        |
|-----------------|-----------------|--------|--------|--------|--------|
|                 | Tank            | A [mm] | B [mm] | C [mm] | D [mm] |
| Black           | 150 L           | 840    | 1200   | 210    | 64     |
|                 | 320 L           | 840    | 1200   | 415    | 64     |

## 3 Components included

### 3.1 Winder

Made of anti-corrosive material with a manual starting crank and lock system.

#### TECHNICAL DATA

- Capacity for 50 m long DN12 hose



### 3.2 Suction oversleeve

Clear flexible PVC spiral absorption oversleeve with rigid PVC spiral and smooth inner surface. Includes non-return foot valve and filter. Includes a Storz connector for connection to the Vallfirest skid unit.

#### TECHNICAL DATA

- Length: 5 m
- Oversleeve diameter: DN25 (1")
- Weight: 2.2 kg (DN25)



### 3.3 Hose

DN12 (1/2") 50 meter semi-rigid hose. Comprised of an inner layer of synthetic rubber reinforced with a metal mesh and coated in abrasion-resistant synthetic rubber. Features a quick water and foam nozzle connection system.

#### TECHNICAL DATA

- SAE 100 R1AT DN12 (1/2"): 160 bar operating pressure, 0.45 kg/m weight



### 3.4 Water nozzle

High-pressure and high-range nozzle. Adjustable angle. Interchangeable ceramic nozzle tip and quick connection system.

#### TECHNICAL DATA

- Maximum pressure: 60 bar
- Maximum flow: 110 L/min.
- Concentrated stream > —
- Hollow cone/fog stream > ◀



## 4 Optional accessories

### 4.1 Foam nozzle

High-pressure and high-range nozzle. Adjustable angle. With quick connection system.\*

#### TECHNICAL DATA

- Maximum pressure: 280 bar
- Maximum flow: 50 L/min
- Concentrated stream > —
- Hollow cone/fog stream > ◀



### 4.2 Foam-forming agent proportioner system

Compact and easy-to-use, foam mixing with a proportional manual selector valve. Creates a stable mix of foam-forming agent in the water. Venturi effect "in line eductor" system which mixes water and foam-forming agent in the drive circuit.



## 5 General dimensions

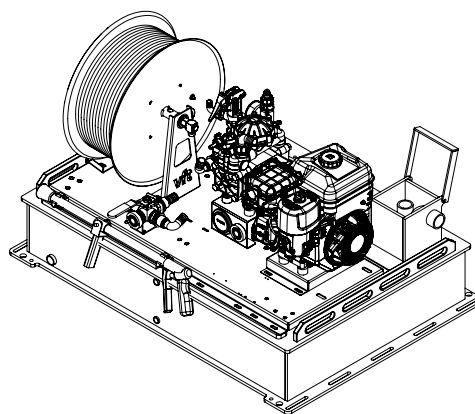
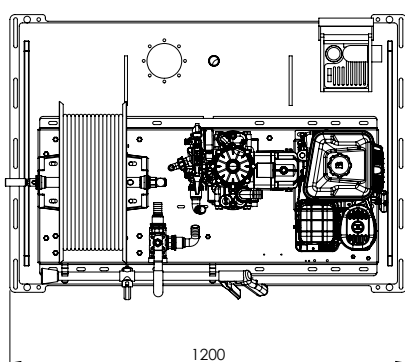
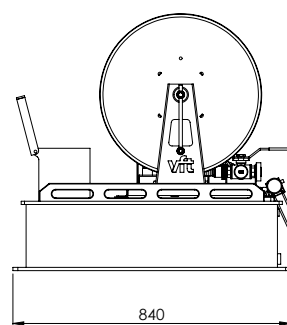
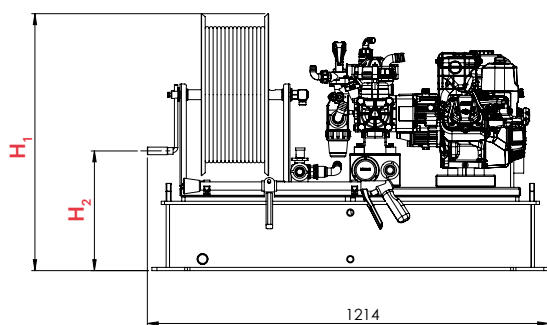

## 6 Configurations available

| Ref. VFT       | Tank   | Motor       | Battery and electric start | Power * | Pump | Max. Pressure** | Max. Flow** | Approx dry Weight | H <sub>1</sub> | H <sub>2</sub> |
|----------------|--------|-------------|----------------------------|---------|------|-----------------|-------------|-------------------|----------------|----------------|
| DVD0815-G30A0  | 150 PP | B&S XR950   | NO                         | 6.5 HP  | AR30 | 40 bar          | 36 l/min    | 780               | 360            |                |
| DVD0815-G31A0  | 150 PP | Honda GX160 | NO                         | 4.8 HP  | AR30 | 40 bar          | 36 l/min    | 780               | 360            |                |
| DVD0832-G30A0  | 320 PP | B&S XR950   | NO                         | 6.5 HP  | AR30 | 40 bar          | 36 l/min    | 980               | 560            |                |
| DVD 0832-G31A0 | 320 PP | Honda GX160 | NO                         | 4.8 HP  | AR30 | 40 bar          | 36 l/min    | 980               | 560            |                |

Gasoline motor.

\* The nominal engine power indicated in this document is the net power tested on a production engine for the engine model pursuant to SAE J1349 (HONDA) / SAE J1940 (Briggs & Stratton) at a specific speed. This value may vary in mass produced motors. The actual output power of the engine installed on the end machine will vary depending on a number of factors such as the applicable engine operating speed, the environmental conditions, maintenance and other variables.

\*\* These values are at direct pump outlet.

\*\*\* The power, pressure and flow values are valid in working conditions: temperature 25°C at sea level. **IMPORTANT:** Engine power will decrease 3.5% for every 300 meters above sea level and 1% for each 5.6°C above 25°C.

Any questions? Contact us: [clientes@vallfirest.com](mailto:clientes@vallfirest.com) | T. +34 938 678 779